

# CROSS CONNECTION BOOTS

THICKNESS OF INSULATION ON BUS

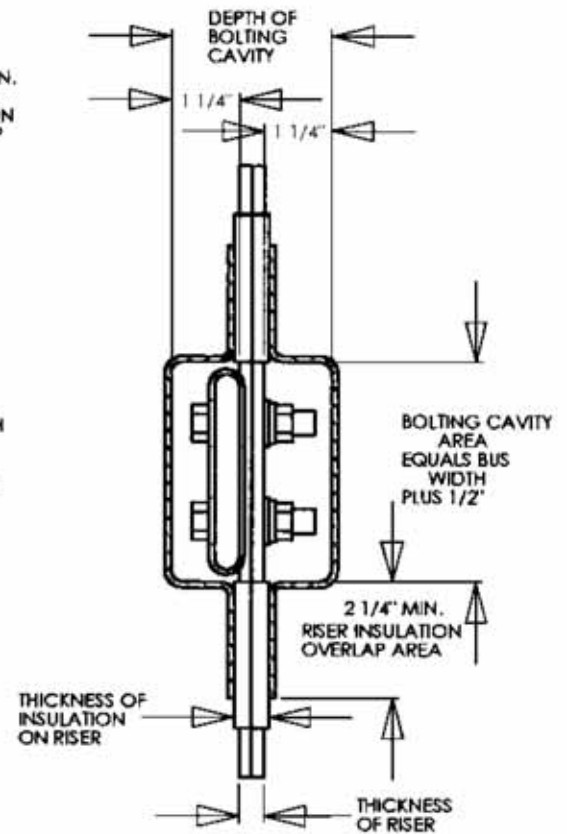
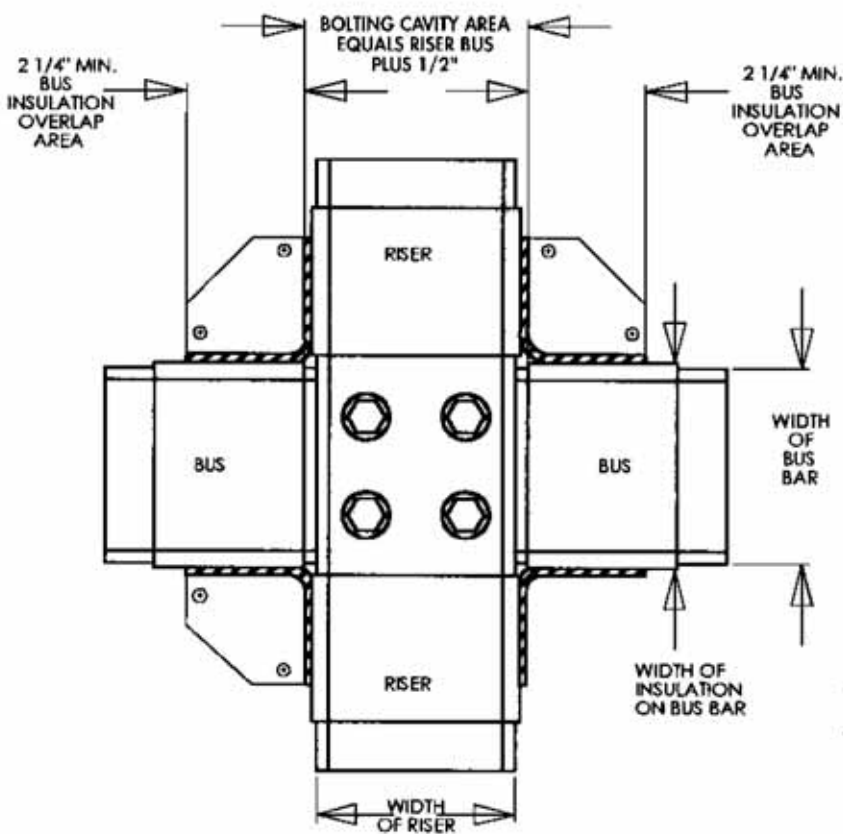
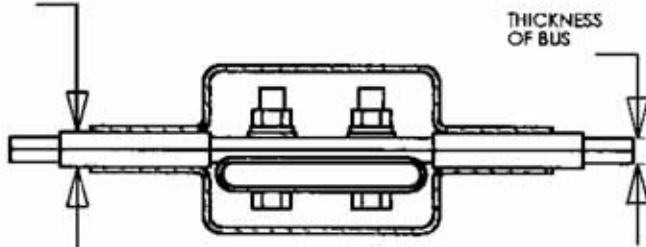

It's easy: just print, fill in and fax to  
01294 311655

**FAST FAX**

## INSULBOOT® CROSS CONNECTIONS

**Standard Range** – Our standard range of Cross connections exceed 200 different configurations. Main Bus size and Riser size range from 1/4" by 2" to 3/4" by 8".

**Free Design Services** – E-mail or fax your Bus layout and we will design and supply drawings of the InsulBoot to suit your needs, usually within 2-3 days. E-mail [sales@insulboot.co.uk](mailto:sales@insulboot.co.uk) or fax 01294 311655

**Custom InsulBoot** – If it is not possible to meet your specifications from our range of standards, we will design and mold a custom InsulBoot to suit your applications, usually within 7 days.

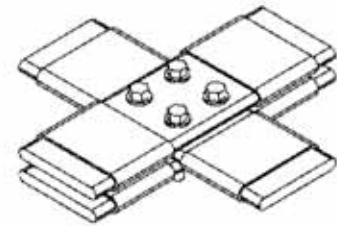
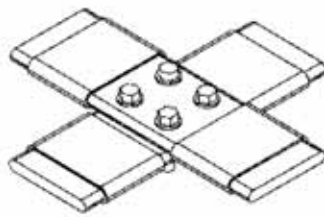

CONNECTOR TYPE  
CHECK ONE:

**1**

**2**

Provide Bus Size:  x   
THICKNESS WIDTH

If PT Tap is required, please mark position and size in sketch area provided.

Provide Tap/  
Riser Size:  x   
THICKNESS WIDTH

Bus Insulation   
THICKNESS

KV Rating

Use this area for additional notes, details or sketch of your own custom needs:

**InsulBoot Only:**

Insulboot Part #

Delivery Time

Price

Name: \_\_\_\_\_ Company: \_\_\_\_\_

Fax: \_\_\_\_\_ Phone: \_\_\_\_\_ E-Mail: \_\_\_\_\_

Quantity: \_\_\_\_\_ Requested Delivery: \_\_\_\_\_

- In Stock  
 Custom

**InsulBoot®**

Fax to 01294 311655 • [www.InsulBoot.co.uk](http://www.InsulBoot.co.uk)