

LEFT END CONNECTION BOOTS

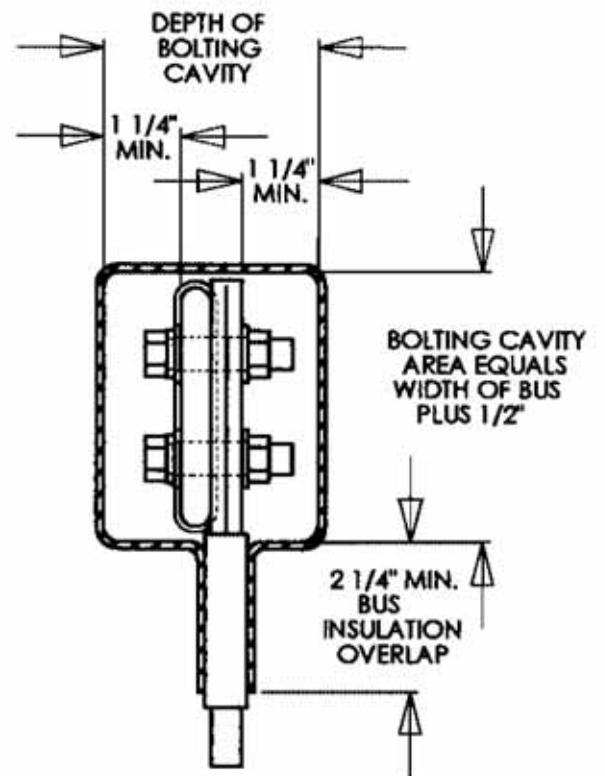
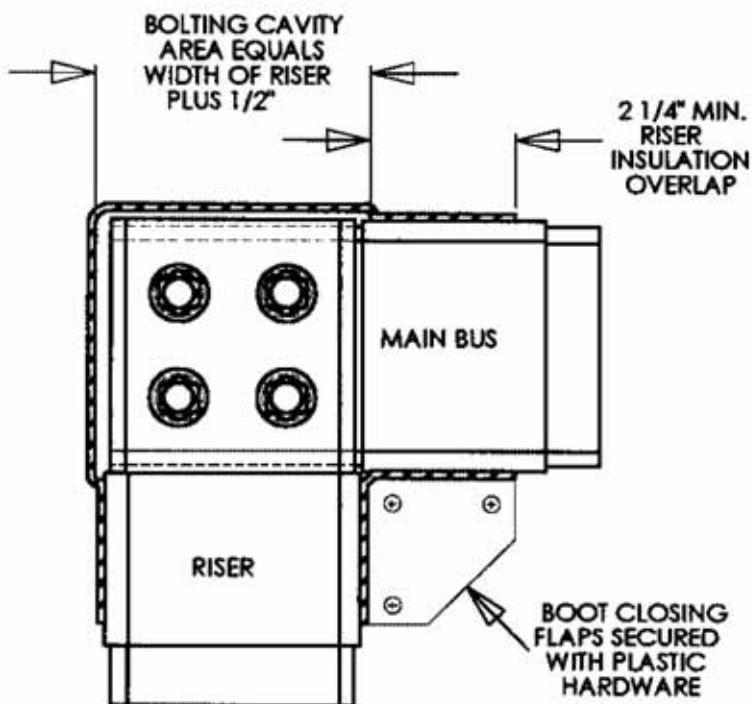

Variations of the above are available.
Cable taps may be added to any configuration.

Fax to 01294 311655 • www.InsulBoot.co.uk

InsulBoot

It's easy: just print, fill in and fax to
01294 311655

FAST FAX

INSULBOOT® LEFT END CONNECTIONS

Standard Range – Our standard range of Left End connections exceed 400 different configurations. Main Bus size and Riser size range from 1/4" by 2" to 3/4" by 8". PT Tap may be added.

Free Design Services – E-mail or fax your Bus layout and we will design and supply drawings of the InsulBoot to suit your needs, usually within 2-3 days. E-mail sales@insulboot.co.uk or fax 01294 311655

Custom InsulBoot – If it is not possible to meet your specifications from our range of standards, we will design and mold a custom InsulBoot to suit your applications, usually within 7 days.

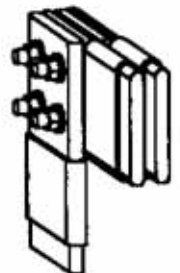
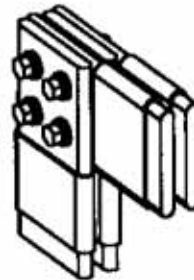
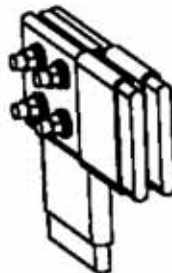
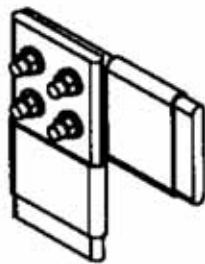

CONNECTOR TYPE
CHECK ONE:

1

2

3

4

Provide Bus Size:

x
THICKNESS WIDTH

If PT Tap is required, please mark position and size in sketch area provided.

Provide Tap/
Riser Size:

x
THICKNESS WIDTH

Bus Insulation

THICKNESS

KV Rating

Use this area for additional notes, details or sketch of your own custom needs:

InsulBoot Only:

Insulboot Part #

Delivery Time

Price

In Stock

Custom

Name: _____ Company: _____

Fax: _____ Phone: _____ E-Mail: _____

Quantity: _____ Requested Delivery: _____

InsulBoot®

Fax to 01294 311655 • www.InsulBoot.co.uk